

# CZ SCORPION EVO3 A1 SUPPRESSOR

## OPERATOR MANUAL

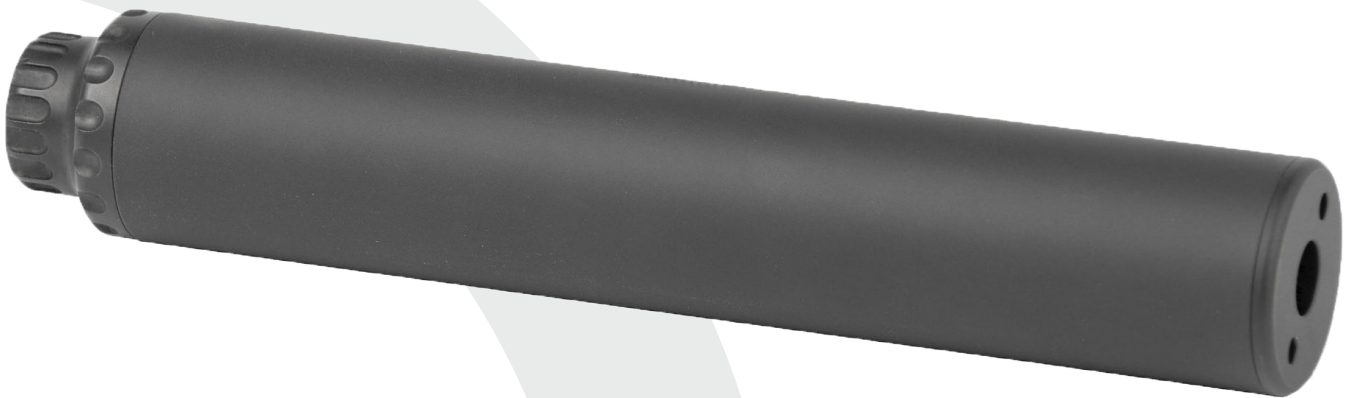

B&T AG  
3608 Thun • Switzerland  
Fon +41 33 334 67 00  
info@bt-ag.ch  
www.bt-ag.ch

**WARNING!**



Suppressed firearms make less noise than non-suppressed firearms, it's easy to forget that they are still firearms. It's of vital importance to remember that a sound suppressed firearm is just as dangerous as a non-suppressed firearm and the same safe handling procedures apply.

Failure to follow the operating instructions can result in serious injury to the user and damage to the firearm. Suppressors are devices that are attached to the muzzle, the muzzle flash hider or a compensator.

A requirement for safe operation is the mounting of the suppressor as described in this operating manual.

Under normal conditions any suppressor will become very hot. This is especially true when fired in full automatic mode. For your safety it is important to allow the suppressor to cool down before touching it in any way, this includes removing the suppressor from the weapon. It is also important not to let the suppressor touch any material or equipment while hot, such as nylon webbing or ammunition pouches.

**EYE PROTECTION MUST BE WORN!**



SAFETY GOGGLES MUST BE WORN WHEN DISASSEMBLING AND REASSEMBLING THE GUN. PARTS CAN GET INTO THE EYES IF HANDLED INCORRECTLY.

**EAR PROTECTION MUST BE WORN!**



SUITABLE HEARING PROTECTION MUST ALWAYS BE WORN WHEN SHOOTING WITH A FIREARM.

## Table of Contents:

1. General rules .....	4
1.1 Safety rules .....	4
1.2 Full automatic firing issues.....	4
1.3 Impact of the shooting position.....	4
2. Technical Specifications .....	5
2.1 Overview - Suppressor Cal. 9 mm CZ Scorpion Evo 3 A1.....	5
2.2 General description .....	5
2.3 Technical data .....	6
2.4 Type description .....	6
3. Mounting & Dismounting .....	7
3.1 Mounting suppressor.....	7
3.2 Dismounting suppressor.....	7
4. Maintenance procedures .....	8
4.1 Storage .....	8
4.2 Field maintenance .....	8
4.3 Workshop Maintenance .....	9
4.3.1 Avoiding corrosion in the suppressor .....	10
5. Accessories.....	11
5.1 Cleaning agent .....	11
6. Warranty statement .....	12

## **1. General rules**

READ MANUAL BEFORE USE.

### **1.1 Safety rules**

1. Consider every weapon loaded until checked personally by the individual operator.
2. User installation or removal of the suppressor must be accomplished in accordance with the instructions contained in this operator manual.
3. Serious injury to the user may result from an improperly installed suppressor.
4. Always wear eye and ear protection when shooting.
5. Check the suppressor for tightness before each use.
6. Don't touch the suppressor after shooting - Suppressors quickly become very hot.

### **1.2 Full automatic firing issues**

Suppressors designed for automatic firearms can be used in fully automatic fire mode. However, it must be taken into account that there is an enormous heat effect when shooting in the fully automatic fire mode. Therefore, it is recommended to shoot with the suppressor on in short bursts and not to fire more than 90 rounds (3 x 30 round magazines). Afterwards, stop shooting if possible and let the suppressor cool down to prevent permanent damage to the suppressor. Eventual further restrictions by the weapon manufacturer must be followed.

### **1.3 Impact of the shooting position**

The additional weight of the suppressor at the muzzle and the different gas conditions directly after the muzzle can change the ballistics of the gun and the point of impact. It is therefore important that the point of impact is always checked with the suppressor and the ammunition before a mission and adjusted if necessary.

## **2. Technical Specifications**

### **2.1 Overview - Supressor Cal. 9 mm CZ Scorpion Evo 3 A1**

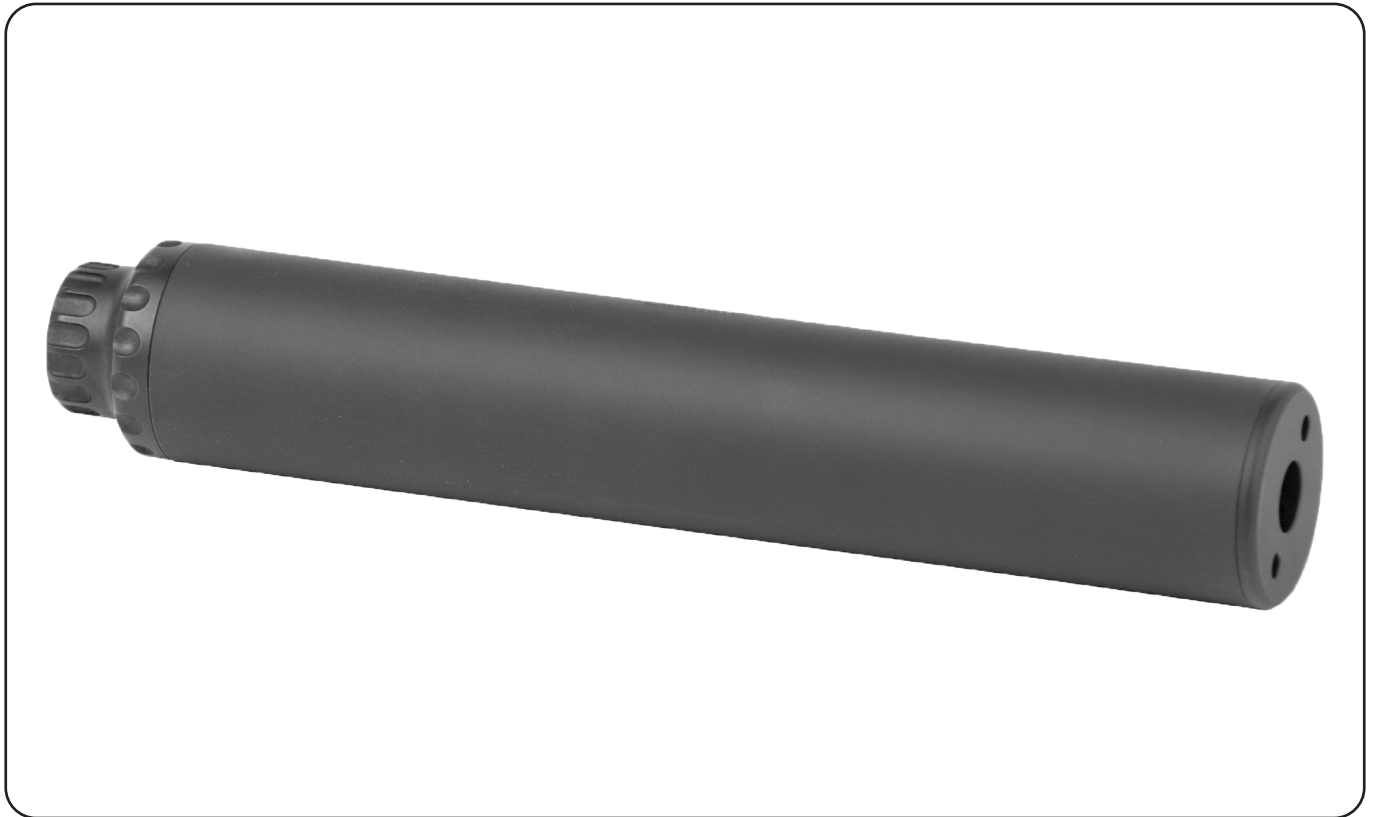

### **2.2 General description**

This version of our proven SMG/MP suppressor is adapted for the use with the CZ Scorpion EVO 3. Due to the fitting thread, the suppressor can be mounted quickly without any tools.

## 2.3 Technical data

<b>Designation</b>	<b>Supressor Cal. 9 mm CZ Scorpion Evo 3 A1</b>
Manufacturer	B&T AG - Switzerland
Product ID	SD-988150
Caliber	9 mm
Weight / Length	0.29 Kg / 202 mm
Extending Length	187 mm
Diameter	35 mm
Suppressor connector	M18 x 1
Sound suppression	Ca. 33 dB (A)
Function	SMG/PDW-Supressor
Material / Color	Alumnium, Stainless Steel / black
Treatment	Anodised
Full Auto capability	90 rounds (3 x 30 rounds magazines)
Life expectancy	min. 5.000 rounds
Ambient temperature range for use	-45°C...70°C

All product specifications are subject to change without notice.

Published data are mean values and therefore not suitable acceptance criteria.

## 2.4 Type description

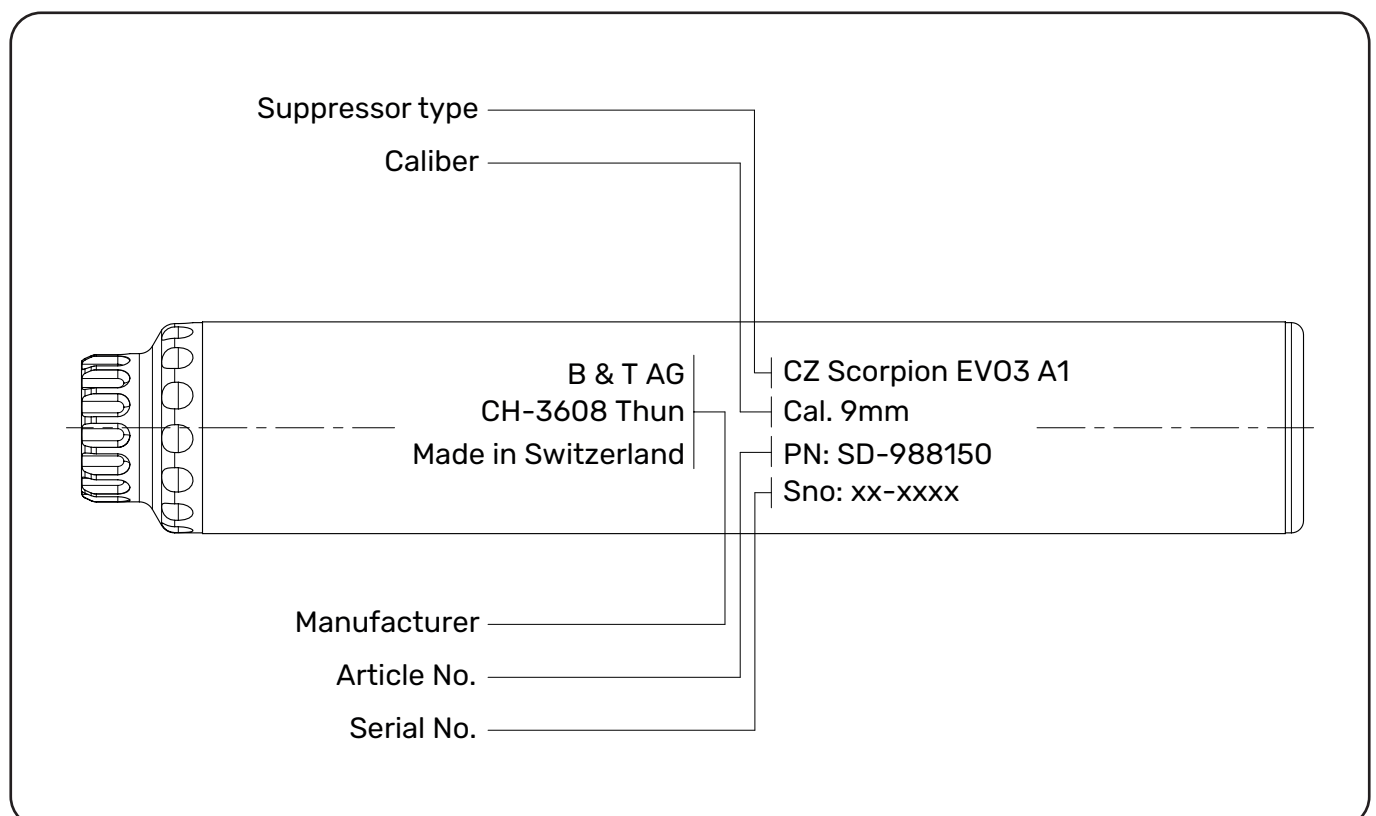

### 3. Mounting & Dismounting

#### 3.1 Mounting suppressor

The CZ Scorpion EVO3 A1 suppressor is made for direct mounting on the barrel, therefore it must be ensured that no flash hider or compensator is mounted before removed.

- a. If possible, clamp the barrel of the gun in a bench vise with soft jaws.
- b. Unscrew and remove the mounted flash hider/compensator.



- c. Clean the thread on the barrel and check it is free from dirt and damage.
- d. Slide the suppressor onto the muzzle thread and tighten it clockwise until it is hand-tight on the thread.



#### 3.2 Dismounting suppressor

- a. Unscrew and remove the suppressor in an anticlockwise direction.



## 4. Maintenance procedures

### 4.1 Storage

Weapons with installed suppressor should be stored upside down with the barrel pointing down. This is especially important after cleaning the suppressor to prevent any cleaning fluid remaining from flowing into the barrel.



### 4.2 Field maintenance

Field maintenance shall be performed in the following sequence:

- » Before use and after a longer period of non-use.
- » Daily for regular use.
- » Immediately after any impact on the suppressor



Regular maintenance in the field includes the following measures:

- » Visual inspection of the inside for foreign bodies and cracks.
- » Visual inspection of the external surfaces for cracks and dents, especially in the muzzle area.
- » Shake the suppressor to detect broken or detached inner parts.
- » Check silencer for tight fit.

#### SICHERHEITSHINWEIS!



If the suppressor has cracks, dents, damage in the muzzle area, loose parts, excessive contamination by carbon particles or other irregularities, it may no longer be used and must be presented to the firearms technician or manufacturer immediately.



### 4.3 Workshop Maintenance

Perform periodic maintenance in the workshop if one or more of the following criteria are met:

- » If sand, mud, water or other liquids got inside the suppressor and then had to be fired without being able to remove the residue from the inside.
- » Immediately after a baffle Strike.
- » 1500 rounds have been fired or every 2 years at the latest.
- » The sound reduction declines noticeably.

To carry out a correct inspection of the suppressor, it must be removed from the weapon in any case. (see chapter „3. Mounting & Dismounting“ on page 7).

Periodic maintenance in the workshop includes the following measures:

1. Visual inspection of the interior for foreign particles and cracks.
2. Visual inspection of the baffles for loose parts, damage and clogged holes.
3. Visual inspection of the external surfaces for cracks and dents, especially in the muzzle area.
4. Shake the suppressor to detect broken or detached inner parts.
5. Check the thread on the muzzle for damage, clean with a small brush and remove grease / oil.
6. Close the suppressor with a plug and fill it with «SchleTek Suppressor-Cleaner Evolution» (or another suitable solvent) for at least 8 hours.
7. Flush out the suppressor with warm water.
8. Blow out the suppressor with compressed air.
9. Grease the thread on the muzzle and the outside of the suppressor with a film of oil.

#### SICHERHEITSHINWEIS!



If the suppressor has cracks, dents, damage in the muzzle area, loose parts, excessive contamination by carbon particles or other irregularities, it may no longer be used and must be presented to the firearms technician or manufacturer immediately.

### 4.3.1 Avoiding corrosion in the suppressor

Moisture inside a suppressor can occur if it is exposed to high humidity (e.g. water, rain...) or if a change in temperature causes condensation inside the suppressor. This moisture is not visible, but can never be completely excluded, even if you did not actually shoot at all and the suppressor was only mounted on the weapon for some time.

This moisture or condensed water, in combination with powder residues, can form a corrosive substance that can damage the suppressor. If this corrosive substance enters the weapon, it can also be damaged. Strong corrosion, including pitting, is hardly to be expected with appropriate care of the suppressor, but in extreme cases could lead to a structural weakening of the suppressor, which is why it must be avoided.

To prevent damage to the suppressor and the weapon due to corrosion, it is important to observe some safety rules:

- a. Always store and transport the weapon and suppressor separately from each other, i.e. do not leave the suppressor on the weapon after use; remove it whenever possible.
- b. If it is not possible to remove the suppressor from the weapon after use, the weapon should be temporarily stored with the muzzle or suppressor down to avoid that corrosive substances from the suppressor enter the muzzle thread and the weapon.
- c. Always keep the inside and outside of the suppressor dry; in case of doubt dry the suppressor before storing it, e.g. putting it in upright position on a radiator (please note weapon legislation!).
- d. When cleaning the weapon and suppressor, always remove the suppressor from the weapon first.
- e. Clean the suppressor regularly with a suitable cleaning agent (e.g. SchleTek Evolution).

#### SAFETY NOTICE!



If these rules are not followed, the suppressor can be structurally weakened by corrosion and, in extreme cases, burst when the shot is fired!  
If these rules are not followed, the weapon may become corroded on the muzzle thread, the compensator or the flashhider, inside the barrel as well as in the weapon itself!

#### SAFETY NOTICE!



If there is any uncertainty as to whether the suppressor is still to be shot, present it to the firearms technician or manufacturer for inspection.

**5. Accessories**  
**5.1 Cleaning agent**

Pos.	Item-No.	Description
	SCT-1986	SchleTek Suppressor-Cleaner Evolution

## 6. Warranty statement

Warranty claims on behalf of the client are to be explicitly declared as such. During the legal warranty period, B&T provides warranty cover solely for defects that arise as a result of faulty materials, construction errors or poor workmanship. If a warranty claim is justified, B&T will, at its own discretion, either repair or replace the defective good. Costs incurred in transporting the defective good to B&T are borne by the Client. Spare parts fitted and replaced become the property of B&T.

Inasmuch as is legally permitted, any other liability of B&T is excluded, in particular liability for damages arising either directly or indirectly from the delivered good itself, from its use or from its defects

Merchandise is covered by the warranty provisions of the manufacturer. Parts that are naturally subject to wear and tear, damage arising from insufficient maintenance work, noncompliance with operating regulations and cases of force majeure are all excluded from warranty cover. Warranty claims lapse if the Client itself or third parties alter or repair the delivered good without the prior written consent of B&T. All product specifications are subject to change without prior notice. Published data are mean values and therefore not suitable acceptance criteria.

The manufacturer:

B&T AG - 3608 Thun - Switzerland

Phone +41 33 334 67 00

e-mail: [info@bt-ag.com](mailto:info@bt-ag.com)